

FORESTRY





CONVINCING PERFORMANCE IN FORESTRY

EPSILON HAS A LOCK ON YOUR LOGS

The manipulation and the harvest of wood demands highest efforts of human and engine. Manipulating in all weather, the operator is expected to work up to his limits. Tough construction, precise controllability and many EPSILON specific solutions make the work easier and more efficient.

The brand PALFINGER EPSILON for decades has stood for solution-orientated and most reliable cranes.

Innovative, technically-superior and our service friendly cranes offer the professional solution for every application in forestry.

Our products are economical over the whole lifetime-cycle and tailored to the individual operation.



Short wood



Long wood



Chipper



Tractor



Forestry trailer



Skidder



Forwarder



Harvester

CONTENT

CONTROL MODE	6
---------------------	---

Epsolution the professional's choice

EPSCOPE	10
EPSLINK	11
LINKAGE SYSTEM	12
PRECISE CONTROLLABILITY	13
CATAPHORETIC PAINTING	14
TIMBER GRABS	15

PRODUCTS

SHORT WOOD CRANES	16
LONG WOOD CRANES	18
CHIPPER CRANES	20
TRACTOR CRANES	22
SKIDDER	23
FORWARDER	24
HARVESTER	25

DEVELOPMENT	26
--------------------	----

PRODUCTION	28
-------------------	----

SERVICE	30
----------------	----



TOP SEAT

Whether in standard version behind the column or as side mounted solution – control from the high seat ensures optimal functionality and ergonomics. The side mounted high seat, alternatively mounted on the left or on the right of the column, offers a completely unlimited view of the whole working area.



LATERAL TOP SEAT



CONTROLS

- » Joysticks / Linear levers
- » Single circuit / double circuit
- » Fixed displacement pump / Variable displacement pump



WEATHER PROTECTION "EPSHOOD"

- » Protection in any weather condition
- » Folds with pneumatic cylinder



CABIN CONTROL

Top efficiency in all weather conditions. Excellent overview thanks to hydraulically raised crane cabin.



MECHANICAL CABIN

- » Joysticks / Linear levers
- » Fixed displacement pump / Variable displacement pump



ELECTRICAL CABIN

- » Joysticks
- » Load Sensing



EPSOLUTION

THE PROFESSIONAL'S CHOICE

With EPSCOPE, EPSLINK and EPSLIGHT EPSILON started a novel concept, which focuses explicitly on the operator's benefit.

The market leader for forestry and recycling cranes considers it most important to find a solution for each customer that is based on his requirements and general feedback. The aim is to generate a professional solution to fulfill the customer's needs and give a tailored solution for the required application area.

EPSILON and SOLUTION become:

Epsolution

EPSCOPE BOOM SYSTEMS

Epsilon

PATENTED DOUBLE TELESCOPE SYSTEM

with extension cylinder and hose equipment mounted inside and protected EPSCOPE allows manipulating without risk of damage.

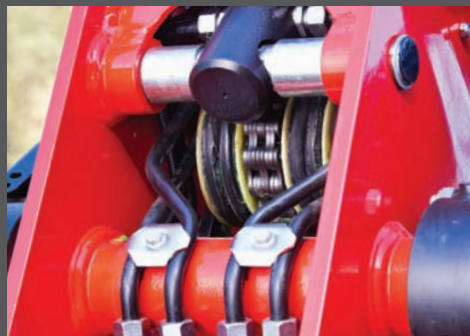

SINGLE TELESCOPE SYSTEM

Also with single telescopes EPSILON comes with internal guided hoses to ensure maximum safety.



EPSLINK LINK-ROTATOR COMBINATION

Epsolution

PATENTED LINK-ROTATOR COMBINATION

Extraordinary four-eye-cast-link with perfect hose guidance, in combination with EPSCOPE the professional solution.



„LOG ALIGNMENT“

This is the most important and most sensitive activity in short wood haulage – simultaneous operation of four crane functions in a period of a tenth second. The possible 90° angle prevents the grab being blocked.



LINKAGE DOUBLE LINKAGE SYSTEM

Evolution

STRONG LINKAGE SYSTEM

Steady force and constant boom speed in the whole operating area



EXTRAORDINARY LIFTING POWER

in upper working area on Z-cranes

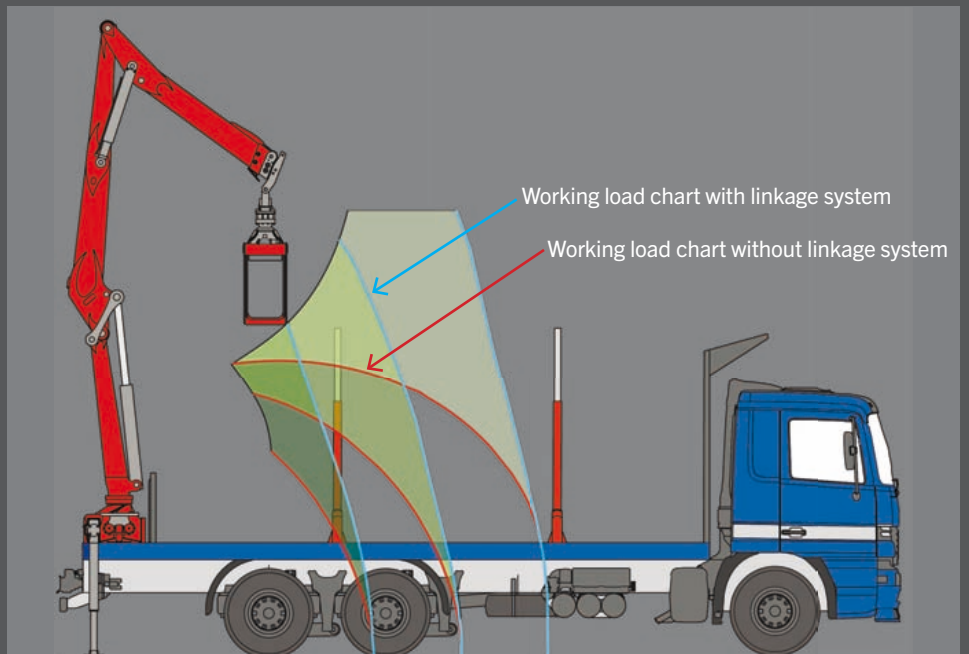

LINKAGE SYSTEM

with L-cranes



PRECISE CONTROL DESPITE HIGH SPEED

Epsolution

DOUBLE SLEWING SYSTEM

- » Double slewing system with endstrokedamping
- » Precise rack and pinion slewing system
- » Floating bearing in oil bath



PERFECT VALVE FINISH

- » Broadly dimensioned control valve, filter and tubing
- » Ergonomically formed control levers with maintenance free links



HIGH-CLASS COMPONENTS

- » Floating bearing in oil bath
- » High grade bronze bushes with greasing channels



KTL CATAPHORETIC PAINTING

Evolution

INNOVATIVE TECHNOLOGY FOR LONG-LASTING SURFACE- PROTECTION

The right surface treatment forms the basis of durable and long-lasting surface protection. The passage of components through the individual process stages of KTL coating is fully automated in the cathodic dip painting plants of the production facilities in Marburg and Lengau. The components are degreased, rinsed, activated, coated with zinc phosphate, rinsed again, passivated and after a final rinse with ultra-pure water are coated electrostatically with the KTL coating in a dip process. Paint robots finalize the surface treatment.

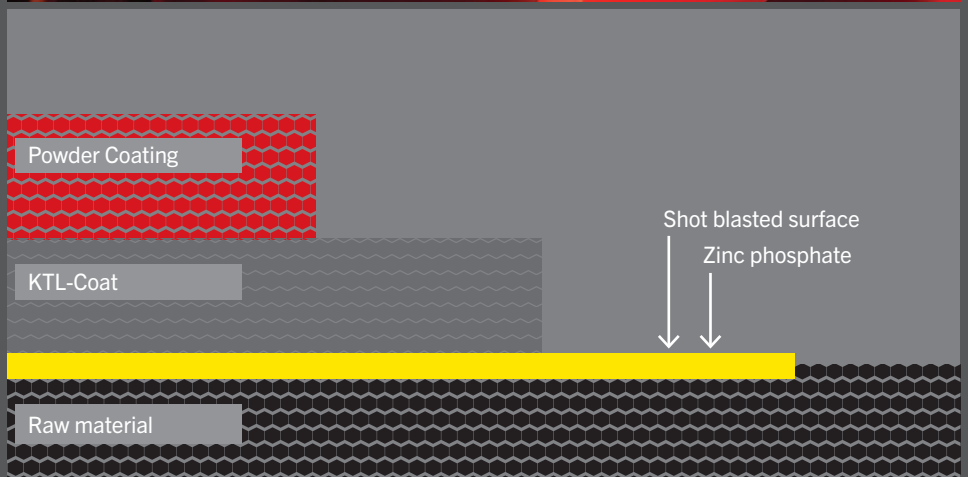

THE TIMBER GRAB

HIGH QUALITY STANDARDS

Epsilon

MAXIMUM LIFE CYCLE

due to hard chrome plated and adjustable bolts, sealed bearing zones as well as bronze bushes with greasing channels. Moreover EPSILON timber grabs come with a perfect unroll feature and ideal footing of the logs. The new designed EPSILON grabs make up everything that belongs to short wood haulage in a professional way. The white painting enables the grab to operate at night as well.





Z-CRANES SHORT WOOD

The compact construction allows the crane to fold across the direction of motion. In this parking position the truck can be loaded up to the legal maximum height.

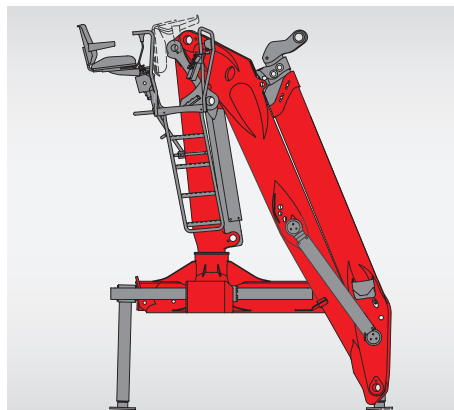

PRODUCT OVERVIEW Z-CRANE

CRANE DESCRIPTION				CRANE TYPE		INTERMEDIATE OPERATION, MAX. 4H/DAY		SHIFT OPERATION, MAX. 8H/DAY	
M	120	Z	96			High seat	Cabin	High seat	Cabin
Class	Lifting moment [kNm]	Z-Crane	Outreach [dm]	C70Z					
C-Compact				C80Z					
M-Medium				M100ZD					
Q-Medium to heavy				M100Z					
				M110Z					
				M120Z					
				M130Z HPLS					
				Q130ZD					
				Q150Z					
				Q170Z					
				Q180Z HPLS					

D - Duration (PRESSURE DEDUCED)
HPLS - High Power Lifting System: + 20 % lifting power, at the same time reduced speed, for short-term operation



L-CRANES SHORT WOOD

L-cranes are equipped with a long main boom and are characterized by high speed and excellent hook clearance. Parking position in this case is above the load respectively on the loading platform.

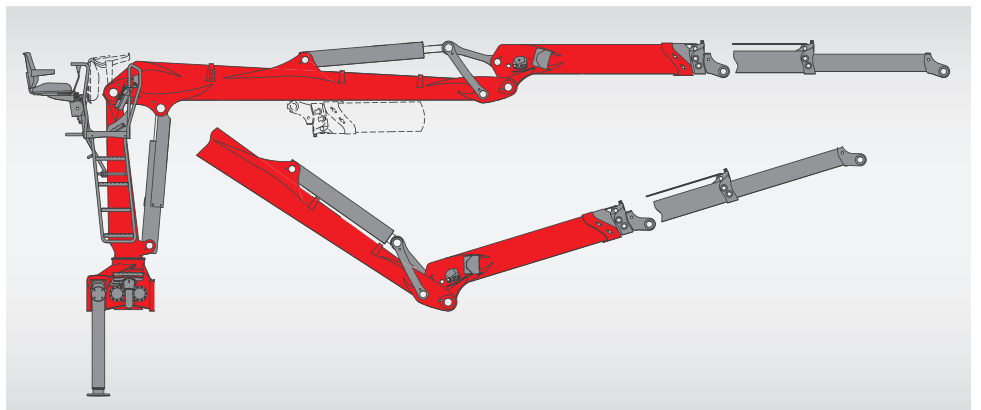

PRODUCT OVERVIEW L-CRANE

CRANE DESCRIPTION				CRANE TYPE		INTERMEDIATE OPERATION, MAX. 4H/DAY		SHIFT OPERATION, MAX. 8H/DAY	
Q	150	L	97		High seat	Cabin	High seat	Cabin	
Class	Lifting moment [kNm]	L-Crane	[dm]	C70L					
C-Compact				C80L					
M-Medium				M100LD					
Q-Medium to heavy				M100L					
				M110L					
				M120L					
				M130L HPLS					
				Q130LD					
				Q150L					
				Q170L					
				Q180L HPLS					

D - Duration (PRESSURE DEDUCED)
HPLS - High Power Lifting System: + 20 % lifting power, at the same time reduced speed, for short-term operation



Z-CRANES LONG WOOD

The compact construction allows the crane to fold across the direction of motion. In this parking position the truck can be loaded up to the legal maximum height. This requires less installation space and reduces weight on front axle.

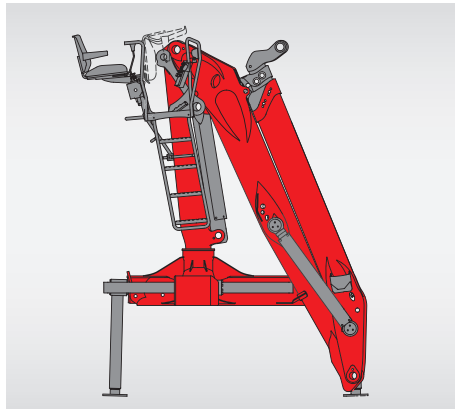

PRODUCT OVERVIEW Z-CRANE

CRANE DESCRIPTION				CRANE TYPE	INTERMEDIATE OPERATION, MAX. 4H/DAY		SHIFT OPERATION, MAX. 8H/DAY	
S	290	Z	96		High seat	Cabin	High seat	Cabin
Class S-Heavy	Lifting moment [kNm]	Z-Crane	Outreach [dm]	S260Z S290Z HPLS				
HPLS – High Power Lifting System: + 20 % lifting power, at the same time reduced speed, for short-term operation								



L-CRANES LONG WOOD

L-cranes come with a long main boom and are characterized by high speed and excellent hook clearance. Parking position in this case is above the truck cabin.

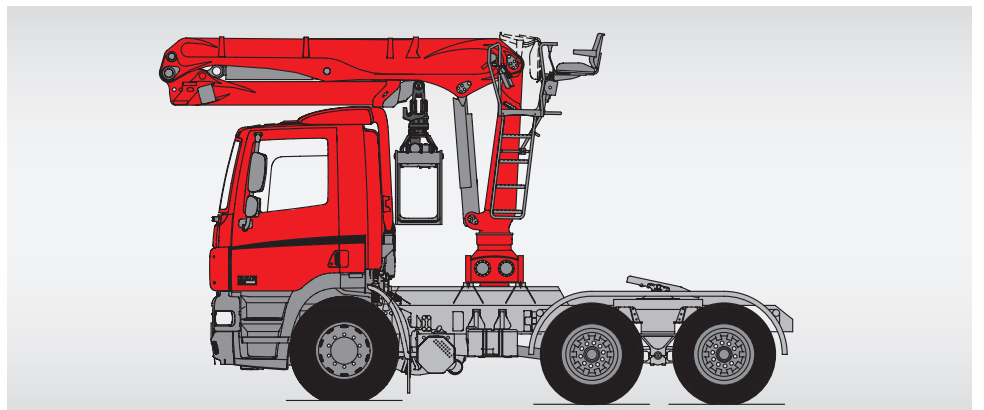

PRODUCT OVERVIEW L-CRANE

CRANE DESCRIPTION				CRANE TYPE		INTERMEDIATE OPERATION, MAX. 4H/DAY		SHIFT OPERATION, MAX. 8H/DAY	
S	300	L	98		High seat	Cabin	High seat	Cabin	
Class S-Heavy	Lifting moment [kNm]	L-Crane	Outreach [dm]	S220L					
				S240L HPLS					
				S260L					
				S290L HPLS					
				S270L					
				S300L HPLS					

HPLS – High Power Lifting System: + 20 % lifting power, at the same time reduced speed, for short-term operation



CHIPPER CRANES

In this application area EPSILON cooperates exclusively with professional OEMs, which integrate the crane control with the control of the chipper. EPSILON stands out in this sector with the largest product and equipment range of the truck and forwarder field.

EPSILON cranes mounted on chippers increase the productivity of the chipper, as all hoses are mounted inside and protected. The grab is also protected with the solutions EPSCOPE and EPSLINK. This way the operator can concentrate completely on chipping.

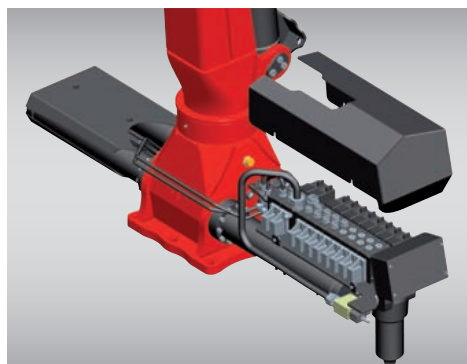

PRODUCT OVERVIEW FORWARDER

SHIFT OPERATION, MAX. 8H/DAY

CRANE DESCRIPTION				CRANE TYPE			ROTATOR		GRABS	JOYSTICKS	CABIN
S	110	F	101								
Class C-Compact M-Medium S-Heavy	Lifting moment [kNm]	Forwarder	Outreach [dm]	C50 F , C60 F							
				M70 F , M80 F							
				S100 F , S110 F							



Larger interior - the cabin offers additional legroom



Air conditioner provides pleasant temperature within the cabin



Convenient working position in air-suspended comfort seat



Adjustable arm rests for ergonomic operation

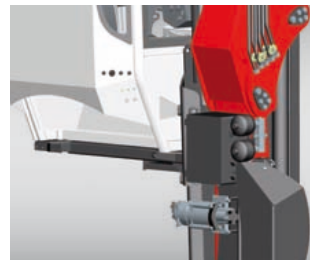

Perfect finish with hydraulic damping



Panorama door for ideal working view

PRODUCT OVERVIEW FORWARDERCRANE

SHIFT OPERATION, MAX. 8H/DAY

CRANE DESCRIPTION					CRANE TYPE	ROTATOR	GRABS	JOYSTICKS	CABIN
Q	130	L	D	97		G121	FG31R		
Class M-Medium Q-Medium to heavy	Lifting moment [kNm]	L-Crane Z-Crane	Duration	Outreach [dm]	M100LD Q130LD	<input type="checkbox"/>	<input type="checkbox"/>	<input type="checkbox"/>	<input type="checkbox"/>
					M100ZD Q130ZD	<input type="checkbox"/>	<input type="checkbox"/>	<input type="checkbox"/>	<input type="checkbox"/>



TRACTOR CRANES

EPSILON's tractor crane models stand out by short parking length, low net weight and compact height. There are plenty of possibilities for individual specification due to the modular construction system.



PRODUCT OVERVIEW TRACTORAPPLICATION

CRANE DESCRIPTION

M	70	F	86
Class C-Compact M-Medium	Lifting moment [kNm]	Forwarder R - Skidder	Outreach [dm]

CRANE TYPE

	ROTATOR			GRABS				
	RB06F	G121	G141	FG27	FG37	FG43S	FG57X	FG31R
C45 F								
C50 F , C60 F								
M70 F , M80 F								
M70 R								
M80 R , M90 R								



SKIDDER

EPSILON long wood skidders stand out especially in this application area by their low and robust method of construction as well as their reliability. Many different boom types give the crane the perfect geometry on each machine, suitable for the individual requirements.

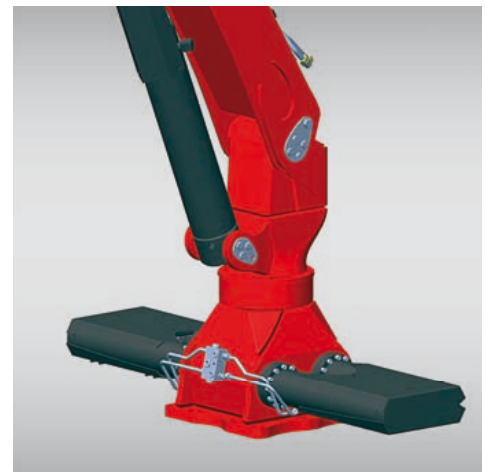

PRODUCT OVERVIEW SKIDDERCRANES

CRANE DESCRIPTION

M	80	R	72
Class M - Medium S - Heavy X - Very Heavy	Lifting moment [kNm]	R - Skidder	Outreach [dm]

CRANE TYPE

	ROTATOR			GRABS				
	RB06F	G121	G141	FG27	FG37	FG43S	FG57X	FG31R
M70R		■			■			
M80R, M90R			■			■		
S110R, S110R			■			■	■	
X130R, X130R			■			■	■	



FORWARDER

EPSILON forwarder cranes – with or without tilt – convince by perfect finish, protected hoses and excellent processing. Wide outreaches with plenty of different boom systems make EPSILON the favourite of all OEMs. EPSLIGHT, a further feature of EPSILON: the most modern LED technology is operated via a linkage system, so that the light is continuously directed towards the working area.

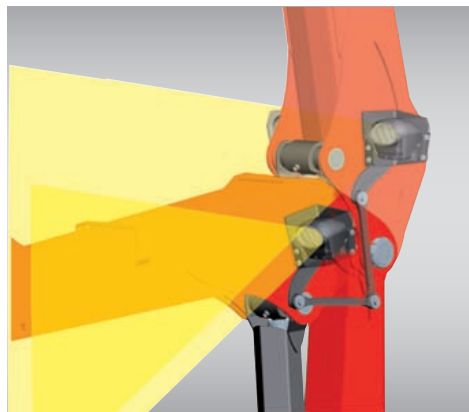

PRODUCT OVERVIEW FORWARDER

CRANE DESCRIPTION

S	100	F	86
Class C-Compact M-Medium S-Heavy X-Very Heavy	Lifting moment [kNm]	Forwarder	Outreach [dm]

CRANE TYPE

C50 F , C60 F	M70 F , M80 F	S100 F , S110 F	X120 F , X140 F
-----------------------------	-----------------------------	-------------------------------	-------------------------------

ROTATOR

RB06 F	G121	G141

GRABS

FG27	FG37	FG43S	FG57X	FG31R



HARVESTER

With the development of the first harvester crane EPSILON has become full range supplier in the OFF ROAD business. As usual EPSILON offers more than a conventional solution – the OFF ROAD product range presents the innovative E+P system, which is applied for a patent.



M	160	H	100	
Class M-Medium	Lifting moment [kNm]	Harvester	Outreach [dm]	Standard equipment
M	160	H	100	EP
Class M-Medium	Lifting moment [kNm]	Harvester	Outreach [dm]	Endless and Protected

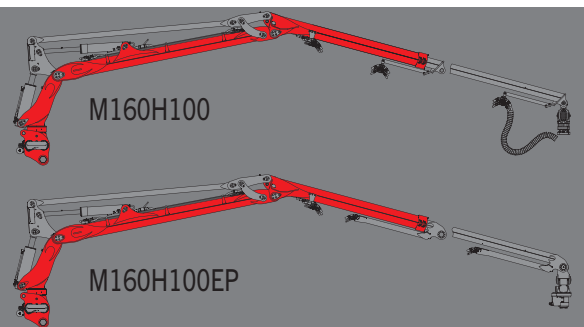

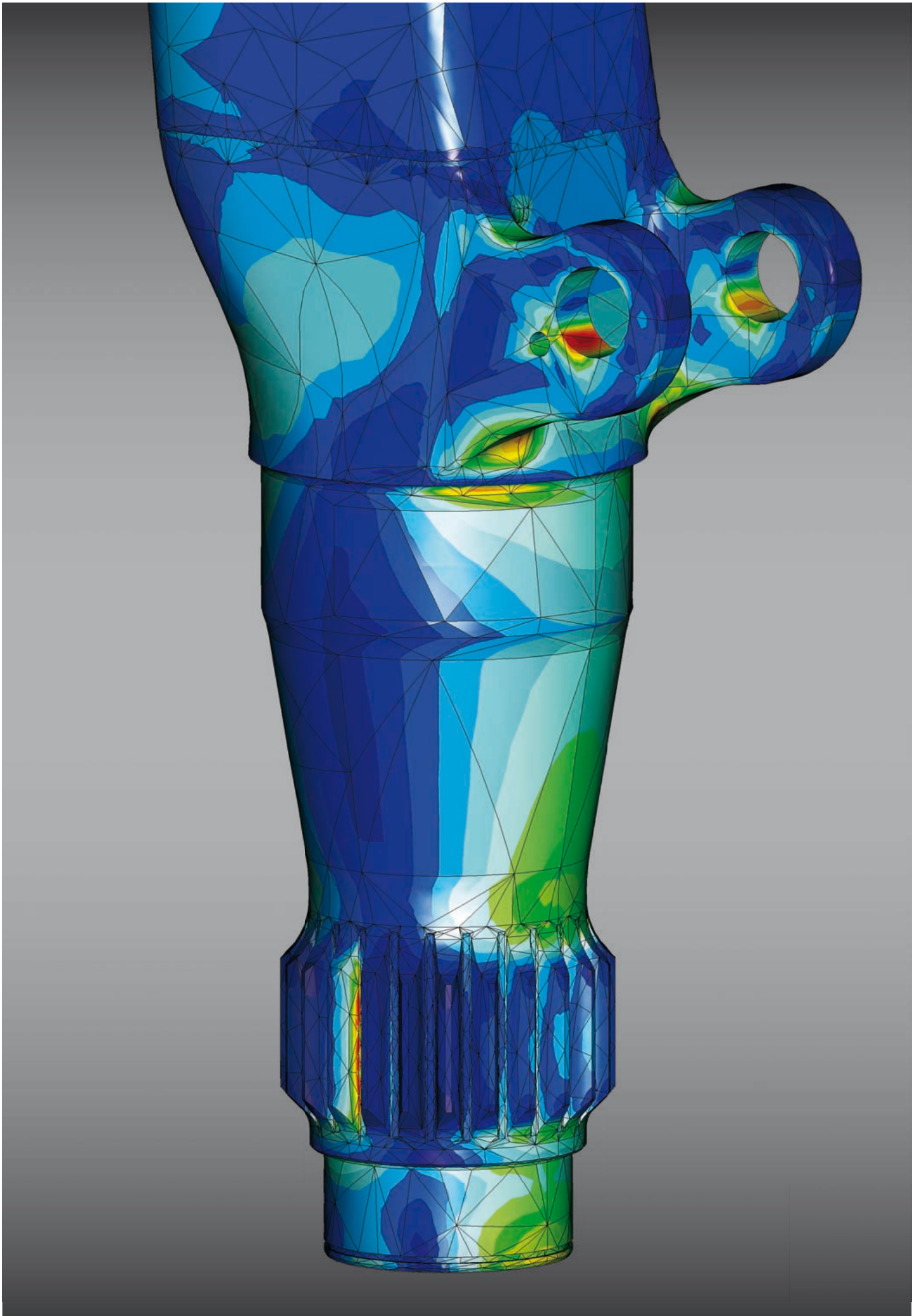

DEVELOPMENT

DURABILITY TEST

The foundation stone for a reliable and successful product is laid in the engineering. Finite element calculations, field and long time tests, strain gauge measurements with appropriate load spectrum ensure an ideal relation between weight and effort. At the center of attention are topics like ergonomics, functionality as well as improvement of weight and raw materials. A high engagement in research & development and cooperation with technical colleges form the base for several patents and perfect working geometry.

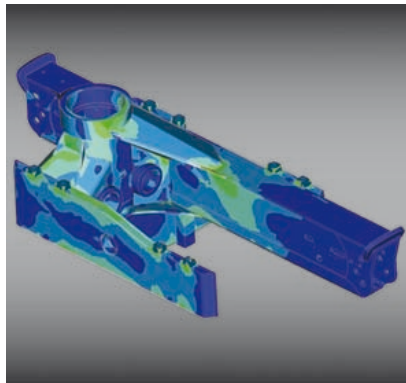

FINITE ELEMENT TECHNOLOGY

High-tech in crane construction: With the finite element technology, all supporting elements have been calculated at EPSILON over years now – optimized with fine grained steel.



CONDITIONING CABINET

Important components of the crane, like control valve and electronic components, are tested in the conditioning cabinet, where they are exposed to extremely low or high temperatures.

STANDARDS



EUROPEAN STANDARDS

All EPSILON standard products come up to the newest machinery directive EN12999. Thus the cranes are CE compliant.



- » **Manometer** as load indicator
- » **Emergency-stop**-function
- » **Choke valve** for lifting, knuckle and telescopic cylinder
- » **Transport position control**
- » **Main boom control**



PRODUCTION

PRECISION IS
OUR SECRET.
QUALITY OUR
PROMISE.

PALFINGER production plants invest permanently in new manufacturing technologies to upgrade the position as technology leader. EPSILON obtains about 80 % of the components from PALFINGER owned production plants. Quality and reliability of welding processes is guaranteed by certification of our welders and regular welding quality audits, carried out by external institutions. All production plants of PALFINGER are ISO certified. PALFINGER's core competences lie primarily in the production of security relevant welded constructions made of high strength fine-grain structural steels, high-tech hydraulic cylinders as well as sustainable durable surface coating technologies (KTL). In the matter of steel processing PALFINGER works on most of the production plants with innovative cutting, edging and welding technologies. Thanks to automated manufacturing technologies high strength fine-grain structural steels can be manipulated precisely.



CYLINDER PRODUCTION

Structural and production engineering expertise. PALFINGER is among the largest producers of hydraulic cylinders with approx. 300,000 cylinders a year leaving the Tenevo plant. PALFINGER coats its cylinders using a particularly high-quality galvanized nickel/chromium process.

SERVICE

PROJECT ENGINEERING

Experienced sales experts advise and support you when selecting a product and the configuration. For optimum vehicle design, the calculation of axle loads, stability and sub-frames EPSILON provides the right software to its dealer network before the sale.

MORE EFFICIENCY IN USE

- » More payload through optimized vehicle configuration
- » Low failure rates
- » Highest equipment availability

SAFE CRANE OPERATION

- » Safety through optimized superstructure calculation
- » Inclusion of country-specific traffic regulations

INCREASED RESALE VALUE

- » Customer-specific truck bodies through long-standing know-how
- » Longer equipment service life thanks to the spare parts guarantee and KTL-painting



RELIABLE SERVICE

With approximately 4,500 sales and service bases worldwide, EPSILON provides an extensive, unbeatable sales and service network. Quickly provided and professional help in service as well as an all-over range of original spare parts. Global player and nevertheless near the customer.



SPARE PARTS SUPPLY

Several spare parts centers worldwide guarantee a seamless supply of spare parts - in Europe within 24 hours. The spare parts warehouse for the areas of Europe, South America and Asia are found in Lengau. On the average, around 1,000 items are processed each day and handled competently and smoothly. The spare parts central warehouse for North America is in the PALFINGER plant in Niagara Falls / Canada. All original spare parts are tested and comply with the PALFINGER quality standard.



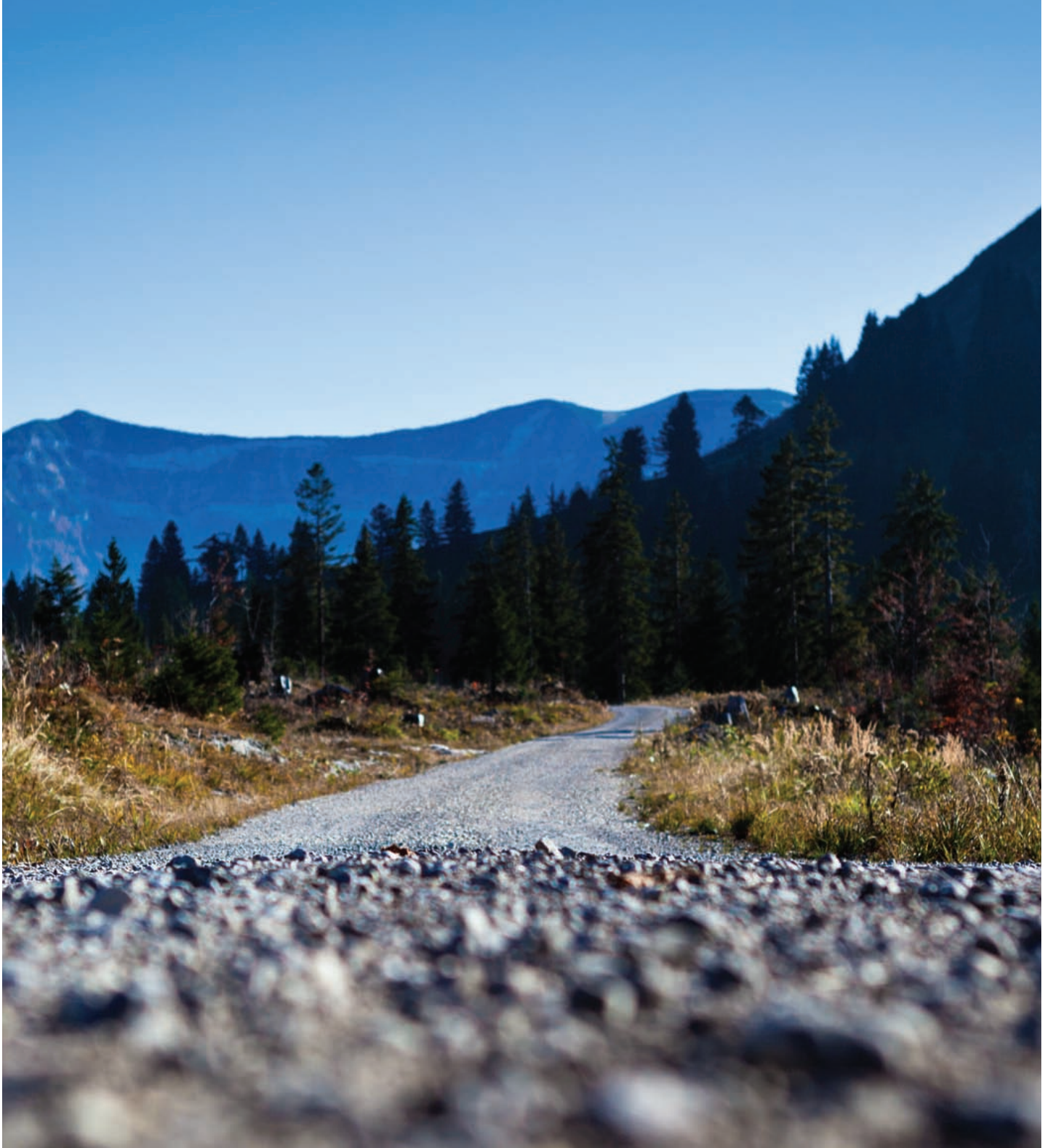

CRANE CONFIGURATOR

For more information about all the available crane models, options and auxiliary equipment please enter the product configurator under www.palfingerepsilon.com

EPSILON Kran GmbH
Christophorusstraße 30
5061 Elsbethen-Glasenbach | Österreich

T +43 662 629548-0
office@epsilonkran.com

WWW.PALFINGEREPSILON.COM

